

MH

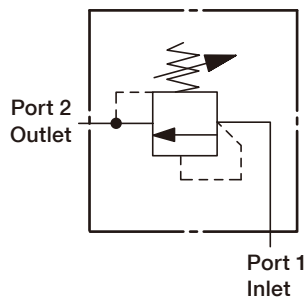

SYMBOLS



ORDER CODES

MH - **082** - **L** **A** **N**

1 2 3 4 5

1	Model Name	MH	
2	Valve Size & Cavity	082, 092, 102	
3	Control Manner	L	standard screw adjustment
		K	hand knob with lock knob
		C	tamper resistant cover
4	Adjustable Range	A	7 ~ 210 bar
		B	3.5 ~105 bar
		C	90 ~ 350 bar
5	Material of Seal	N	buna-N
		V	viton

MODEL SPEC.

Model	Cavity	Capacity (l/min)	Max. Pressure (bar)	Installation Torque (Nm)	Operational Temperature	Weight (kg)
MH-082	T082	25	350	40/50	-35 ~ 100°C (-31 ~ 212°F)	0.15
MH-092	T092	45	350	40/50		0.25
MH-102	T102	55	350	40/50		0.20

PERFORMANCE CURVES

► Typical Pressure Rise

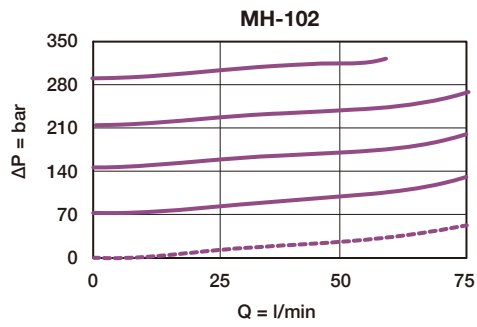
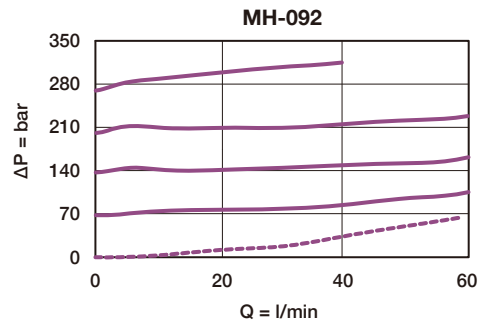
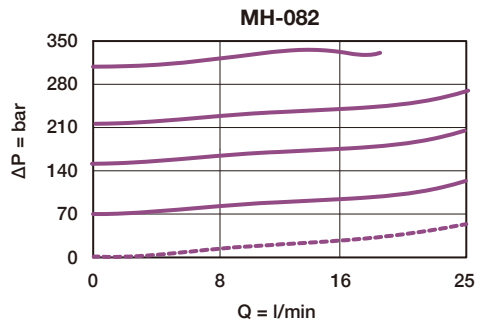

DIMENSION

(UNIT : mm)

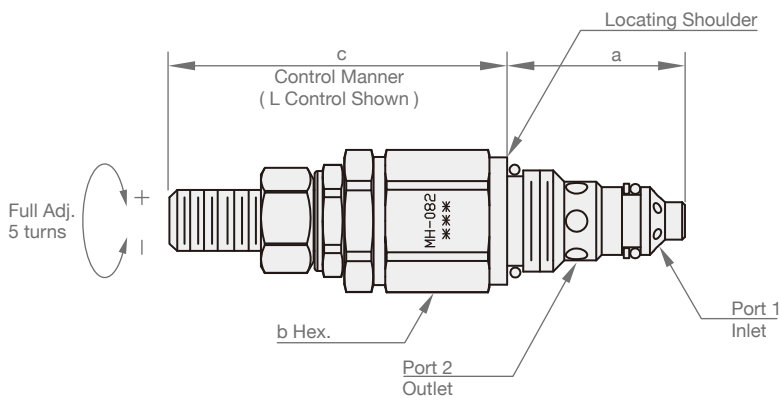

Model	a	b	c	
			L	K
MH-082	34	24	60	66
MH-092	54	26	58	93
MH-102	38.8	25.4	58	64